

# RobotLogic

[www.robotlogic.com](http://www.robotlogic.com)

## Servo Tester Users Guide

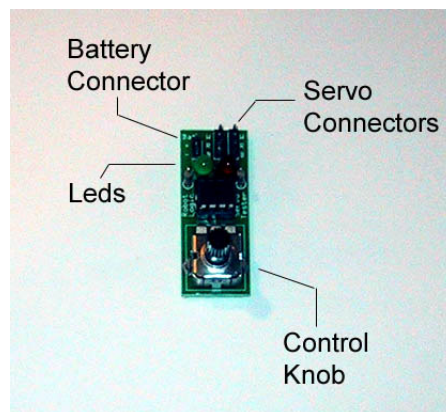

## Introduction

The RobotLogic Servo Tester uses a microprocessor to accurately reproduce RC servo pulses. The actual pulse generated is controlled by turning the input knob to the left and right. Pulses between 1 ms and 2 ms can be generated, which should provide 90 degrees of rotation on most servos. The two LEDs on the board give feedback on the servo pulse currently being generated. The RobotLogic Servo Tester has a battery connector for a standard 4-cell receiver battery and two servo connectors.

## Setup

Supply between 4.5V and 6.0V to the board by connecting a receiver battery pack to the battery connector posts. A standard 4-cell receiver battery works best for powering the servo tester.

When connecting your battery and RC device to the servo tester, ensure that you orient the connectors according to the labels on the board. For all connections, the ground wire should be oriented towards the inside of the board.

## LED Feedback

As mentioned above, the LED's on the board provide feedback on the servo pulse being generated. The LEDs will alternately blink on powerup for a second. At the two extremes one of the LEDs will blink and at the center they will both be on solid. A complete table of the LED states is shown below:

<b>Green LED</b>	<b>Red LED</b>	<b>Servo Pulse</b>
Blinking	Off	Max "left"
On	Off	To the "left" of center
On	On	Centered
Off	On	To the "right" of center
Off	Blinking	Max "right"

**LEGAL DISCLAIMER:**

THIS PRODUCT IS PROVIDED "AS IS" WITHOUT ANY EXPRESS OR IMPLIED WARRANTY OF ANY KIND INCLUDING WARRANTIES OF MERCHANTABILITY, NONINFRINGEMENT OF INTELLECTUAL PROPERTY, OR FITNESS FOR ANY PARTICULAR PURPOSE. IN NO EVENT SHALL ROBOT LOGIC OR ITS SUPPLIERS OR DISTRIBUTORS BE LIABLE FOR ANY DAMAGES WHATSOEVER (INCLUDING, WITHOUT LIMITATION, DAMAGES FOR LOSS OF PROFITS OR BUSINESS INTERRUPTION) ARISING OUT OF THE USE OF OR INABILITY TO USE THE MATERIALS, EVEN IF ROBOT LOGIC HAS BEEN ADVISED OF THE POSSIBILITY OF SUCH DAMAGES. BECAUSE SOME JURISDICTIONS PROHIBIT THE EXCLUSION OR LIMITATION OF LIABILITY FOR CONSEQUENTIAL OR INCIDENTAL DAMAGES, THE ABOVE LIMITATION MAY NOT APPLY TO YOU.

Robot Logic and its suppliers further do not warrant the accuracy or completeness of the information, text, graphics, links or other items contained within product datasheets or this website. Robot Logic may make changes to these materials, or to the products described therein, at any time without notice. Robot Logic makes no commitment to update the Materials.