

**UCTRONICS**®

**Arduino Smart Bluetooth Robot Car  
Kit**

**User Guide**



**UCTRONICS**

# Table of Contents

- 1. Introduction .....4
  - 1.1 Packing list.....5
- 2. Assembly.....6
  - 2.1 Arduino Uno R3.....6
    - 2.1.1 Specifications.....6
  - 2.2 HC-SR04 Ultrasonic Sensor Module with Bracket / Holder.....7
    - 2.2.1 Working Principle.....7
    - 2.2.2 Specification.....8
    - 2.2.3 Wiring diagram:.....9
  - 2.3 L293D Motor Drive Expansion Board for Arduino .....9
    - 2.3.1 Specification.....9
  - 2.4 SG90 9g micro small servo motor ..... 10
    - 2.4.1 Specification..... 11
  - 2.5 2WD Driver Motor Encoder Robot Smart Car Chassis Kits..... 11
    - 2.5.1 Specification..... 11
  - 2.6 HC-05 Bluetooth Serial transmission Wireless Module ..... 12
    - 2.6.1 Specification..... 12
    - 2.6.2 Pin definition ..... 13
    - 2.6.3 Application: ..... 13
  - 2.7 Infrared IR Wireless Remote Control Sensor Module Kits..... 14
    - 2.7.1 Specification..... 14
    - 2.7.2 Dimension ..... 15
- 3. Pin Definition..... 16
- 4. Wiring ..... 17
- 5. Installation ..... 18
  - 5.1 Installation of the Components..... 18
  - 5.2 Installation of the Car ..... 20
- 6. Key Value for Remote Controller..... 27

- 7. Start Programming..... 28
  - 7.1 Install Arduino IDE ..... 28
  - 7.2 Add Libraries..... 32
- 8. Bluetooth App for Android..... 35
  - Step 1: Download and Install App ..... 35
  - Step 2: Open UCTRONICS\_Car\_Controller software, the default is Bluetooth Mode ..... 36
  - Step 3: Click the top right and choose 'Connected device' ..... 36
  - Step 4: Select 'CAR CONTROL MODE' ..... 37
  - Step 5: Search Bluetooth Device ..... 37
  - Step 6: Enter control menu ..... 38
  - Step 7: Click the top right and choose 'Change to wifi mode' ..... 38

# 1. Introduction



The UCTRONICS Smart Bluetooth Robot Car Kit is a flexible vehicular kit particularly designed for education, competition and entertainment.

The kit has an intelligence built in so that it guides itself whenever an obstacle comes ahead of it. An Arduino development is used to achieve the desired operation. With the help of a small servo motor, it scans the area left and right in order to find the best way to turn. An ultrasonic sensor unit is used to detect any obstacle ahead of it that sends a command to the Arduino Board. Depending on the input signal received, the Arduino microcontroller redirects the robot to move in an alternate direction by appropriately actuating the motors interfaced to it through a motor driver IC.

When all the necessary components are getting together, a robot car comes up!

A robot is a machine that can perform some task automatically or with guidance. Robotics is generally a combination of computational intelligence and physical machines (motors). Due to their high level of performance and reliability, the robot get the splendid popularity in our daily life.

Come up, let's go into a Robot World!

## 1.1 Packing list

- 1pcs Arduino UNO R3 Board
- 1pcs HC-SR04 Ultrasonic Sensor Module
- 1pcs Holder for HC-SR04
- 1pcs L293D Motor Drive Expansion Board
- 1pcs 9g micro servo motor
- 1pcs servo motor Bracket
- 1pcs Infrared IR Wireless Remote Control Sensor Module Kits
- 1pcs HC-05 Bluetooth Serial transmission Wireless Module
- Some cables and pin headers as a gift
- 1set Car Chassis Kits:
  - 2pcs 65mm tire Wheels
  - 2pcs Geared Motors (1:48)
  - 2pcs Speed Encoders
  - 1pcs Universal Wheel
  - 1pcs Battery Box
  - 1pcs Car Chassis
  - 1pcs Switch
  - Screws+ Nuts

## 2. Assembly

### 2.1 Arduino Uno R3

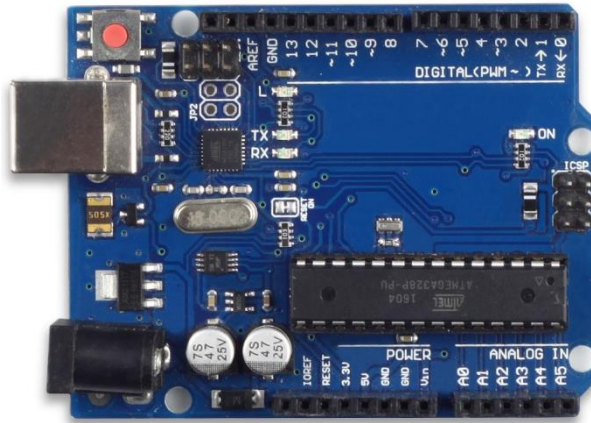

This is the new Arduino Uno R3. In addition to all the features of the previous board, the Uno now uses an ATmega16U2 instead of the 8U2 found on the Uno (or the FTDI found on previous generations). This allows for faster transfer rates and more memory. No drivers needed for Linux or Mac (.inf file for Windows is needed and included in the Arduino IDE), and the ability to have the Uno show up as a keyboard, mouse, joystick, etc.

The Uno R3 also adds SDA and SCL pins next to the AREF. In addition, there are two new pins placed near the RESET pin. One is the IOREF that allow the shields to adapt to the voltage provided from the board. The other is a not connected and is reserved for future purposes. The Uno R3 works with all existing shields but can adapt to new shields which use these additional pins.

Note: The Arduino Uno R3 requires the Arduino 1.0 drivers folder in order to install properly on some computers. We have tested and confirmed that the R3 can be programmed in older versions of the IDE. However, the first time using the R3 on a new computer, you will need to have Arduino 1.0 installed on that machine. If you are interested in reading more about the changes to the IDE, check out the official Arduino 1.0 Release notes!

#### 2.1.1 Specifications

- Microcontroller: ATmega328
- Operating Voltage: 5V
- Input Voltage (recommended): 7V-12V

- Input Voltage (limits): 6V-20V
- Digital I/O Pins: 14 (of which 6 provide PWM output)
- Analog Input Pins: 6
- DC Current per I/O Pin: 40 mA
- DC Current for 3.3V Pin: 50 mA
- Flash Memory: 32 KB (ATmega328) of which 0.5 KB used by bootloader
- SRAM: 2 KB (ATmega328)
- EEPROM: 1 KB (ATmega328)
- Clock Speed: 16 MHz

## 2.2 HC-SR04 Ultrasonic Sensor Module with Bracket / Holder



The HC-SR04 ultrasonic sensor module for Arduino is used for obstacle detection. Ultrasonic sensor transmits the ultrasonic waves from its sensor head and again receives the ultrasonic waves reflected from an object.

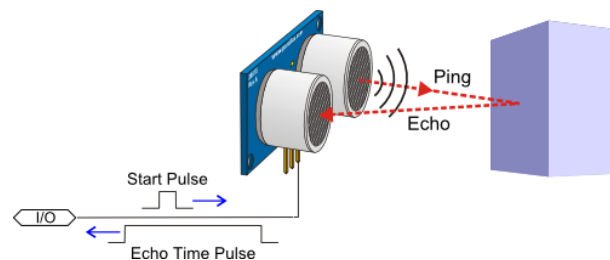

Ultrasonic sensor general diagram

### 2.2.1 Working Principle

The ultrasonic sensor emits the short and high frequency signal. These propagate in the air at the velocity of sound. If they hit any object, then they reflect back echo signal to the

sensor. The ultrasonic sensor consists of a multi vibrator, fixed to the base. The multi vibrator is combination of a resonator and vibrator. The resonator delivers ultrasonic wave generated by the vibration. The ultrasonic sensor actually consists of two parts; the emitter which produces a 40kHz sound wave and detector detects 40 kHz sound wave and sends electrical signal back to the microcontroller.

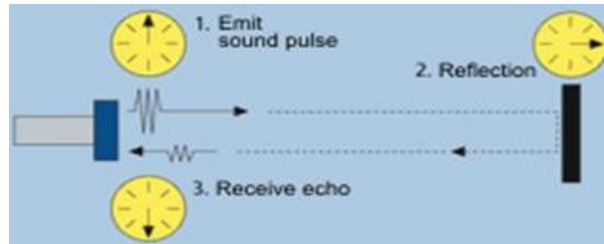

Ultrasonic working principle

The ultrasonic sensor enables the robot to virtually see and recognize object, avoid obstacles, measure distance. The operating range of ultrasonic sensor is 2 cm to 450 cm.

### 2.2.2 Specification

- Working Voltage: 5V DC
- Static current: < 2mA
- Output signal: Electric frequency signal
- Output Voltage: 0V-5V
- Sensor angle:  $\leq 15^\circ$
- Detection distance: 2-450cm
- High precision: Up to 0.3cm
- Input trigger signal: 10us TTL impulse
- Echo signal: output TTL PWL signal
- Mode of connection: VCC, trig (T), echo, GND
- Using method:
  - (1) Supply module with 5V
  - (2) Output will be 5V while obstacle in range, otherwise it will be 0V
- Item size: 44x20x15mm

2.2.3 Wiring diagram:

HC-SR04 Ultrasonic Sensor Module	Arduino
VCC	5V
Trig	A2
Echo	A3
GND	GND

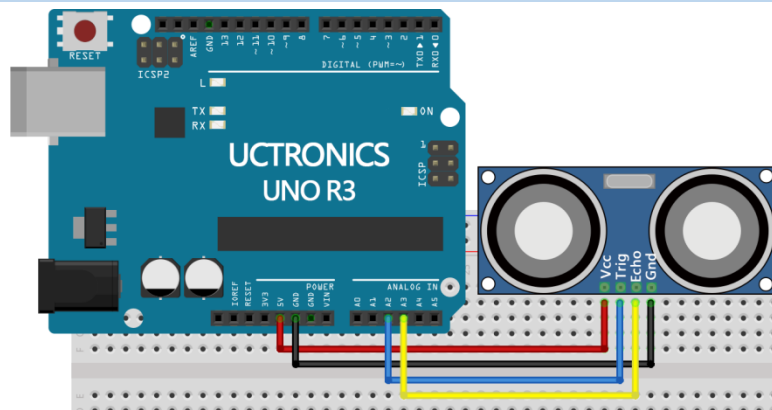

2.3 L293D Motor Drive Expansion Board for Arduino

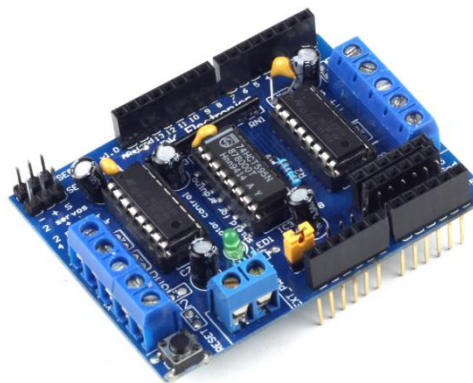

This is a commonly used DC motor drive module, using L293D chip with small current DC motor driver. The pins are made compatible with Arduino which is easy to use.

2.3.1 Specification

- 2 connections for 5V servos connected to the Arduino's high-resolution dedicated timer
- Up to 4 bi-directional DC motors with 4 PWM speed regulation
- Up to 2 stepper motor control, single / double step control, staggered or microstepping

and rotation angle control

- 4 H-Bridges: L293D chipset provides 0.6A per bridge (1.2A peak) with thermal shutdown protection, 4.5V to 36V
- Pull down resistors to keep motors in the state of rest during power-up
- Large terminal terminals make wiring easier (10 - 22AWG)
- With Arduino reset button
- The 2 terminals are connected to the external power supply terminals to ensure the separation of the logic and the motor drive power

Voltage	DC 3V	DC 5V	DC 6V
Current	100MA	100MA	120MA
Reduction rate	48:1		
RPM (with tire)	100	190	240
Tire Diameter	66mm		
Car Speed (M/minute)	20	39	48
Motor Weight (g)	50		
Motor Size (mm)	70x22x18mm		
Noise	<65dB		

## 2.4 SG90 9g micro small servo motor



SG90 9g micro small servo motor is the main source of controlling action of the remote-control model. The module is widely applied in the field of fixed wing, helicopter,

gliding, small robot, manipulator model.

### 2.4.1 Specification

- Size: 23x12.2x29 mm
- Torsional moment: 1.5kg/cm
- Working voltage: 4.2V-6V
- Temperature range: 0°C -55°C
- Operating speed: 0.1 seconds /60°
- Dead band width: 10 microseconds

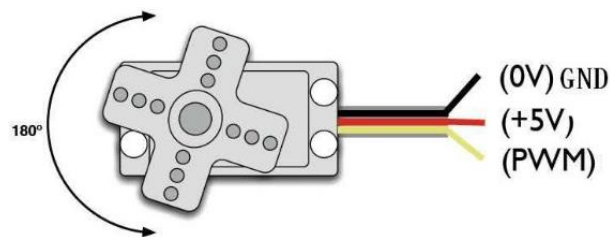

### 2.5 2WD Driver Motor Encoder Robot Smart Car Chassis Kits

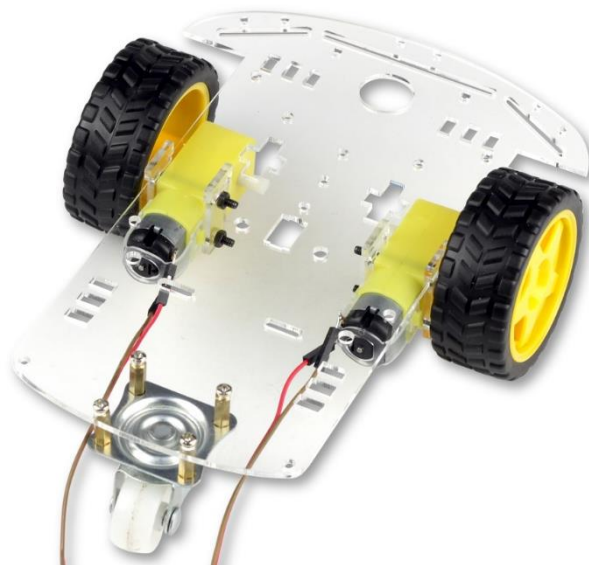

With the car platform, adding micro-controller (such as Arduino) and sensor modules, then program it, a robot car comes up.

All the module interface has been modified with XH2.54 ports as to make it much easier and convenient to assemble the car and reduce the chances for errors.

### 2.5.1 Specification

- The car is the tachometer encoder
- With battery box
- Gear Motor reduction radio: 48:1
- Apply in distance measurement, velocity

## 2.6 HC-05 Bluetooth Serial transmission Wireless Module



This module is mainly used in the field of wireless transmission of data over short distances. It can be easily connected to PC Bluetooth device and also can exchange data between two modules. Direct serial cable replacement avoid the cumbersome cable connections.

### 2.6.1 Specification

- Interface: VCC, GND, TXD, RXD, KEY, STATE (Note: The Pin for STATE, low output when unconnected, high out when after the connection)
- LED indicates the connection state of the Bluetooth, quick flash indicates no connection, slow flash indicates the module enter into the AT mode, double flash indicates the successfully connection of the Bluetooth and the open port
- The bottom plate is set to an anti-reverse diode with 3.3V LDO, the input voltage 3.6-6V, unpaired current is 30mA, 10mA after pairing, the input voltage is prohibited more than 7V
- Interface level 3.3V which can be directly connected to a variety of single-chip (51, AVR, PIC, ARM, MSP430, etc.), 5V microcontrollers can also be directly connected which can not pass through MAX232 chip
- Available to pull the 34 feet into the AT command mode setting parameters and



## 2.7 Infrared IR Wireless Remote Control Sensor Module Kits



The wireless infrared remote controlling kits by mini ultra-thin infrared remote controller and LF0038M infrared receiving module, mini slim infrared remote control with 17 function keys and launch the farthest distance up to 8 meters, it is suitable for the indoor control a variety of devices. The infrared receiving module can receive the remote control signal which is modulated by the standard 38 KHz, and the decoding operation of the remote control signal can be realized by programming the remote control signal.

### 2.7.1 Specification

Remote control:

- 8 address bit, 8 order bit
- Carrier frequency: 38kHz
- Transmission Distance: up to 8m
- Sticking material: 0.125mmPET
- Lift cycle: 20,000 times

LF0038M infrared receiver:

- Operating voltage: 2.7V-5.5V
- Receiving distance: 15m-18m
- Output: TTL, CMOS level, active low
- Anti-dry ability
- Epoxy plastic encapsulation

2.7.2 Dimension

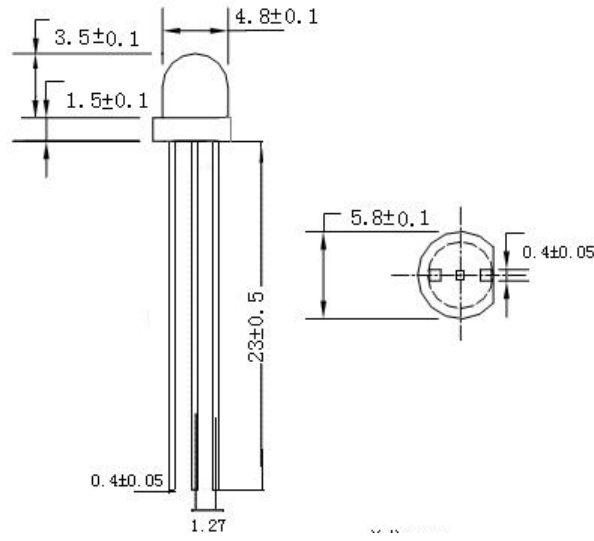

Infrared receiver

### 3. Pin Definition

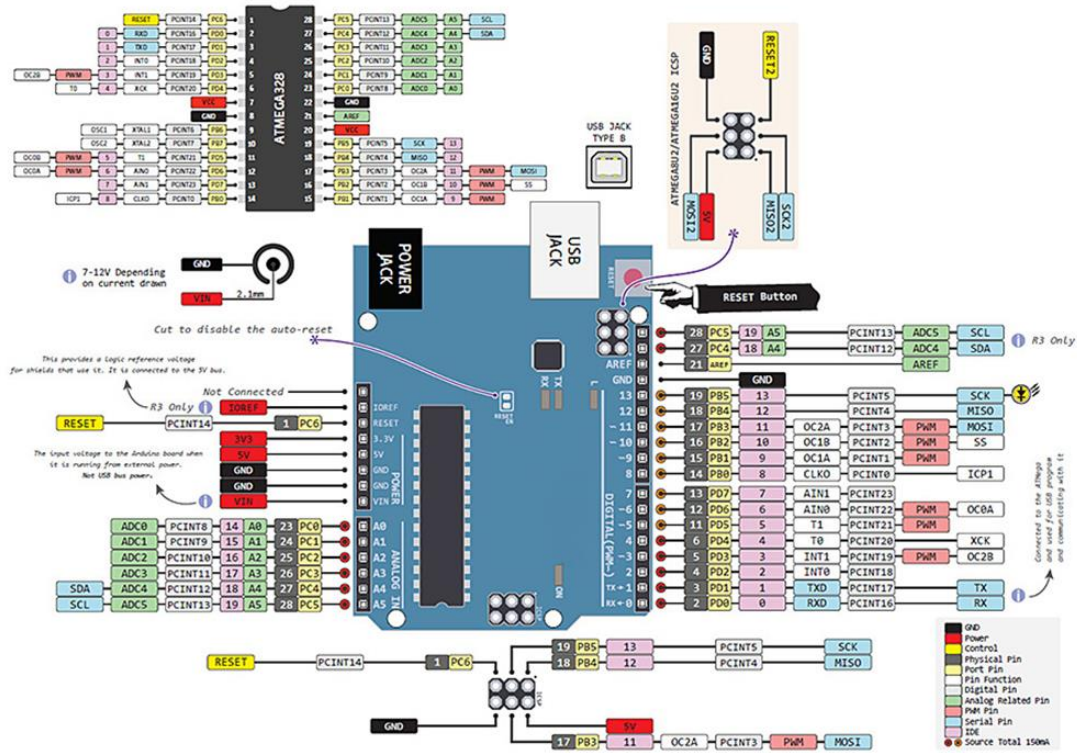

Arduino UNO R3 Board

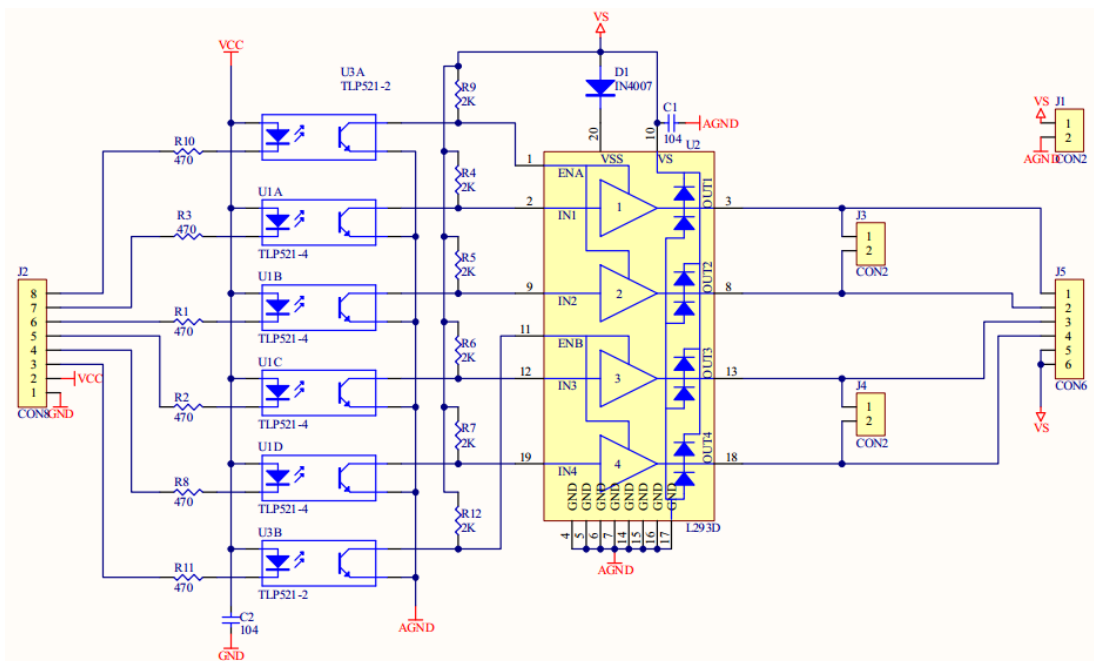

L293D Motor Drive Expansion Board

# 4. Wiring

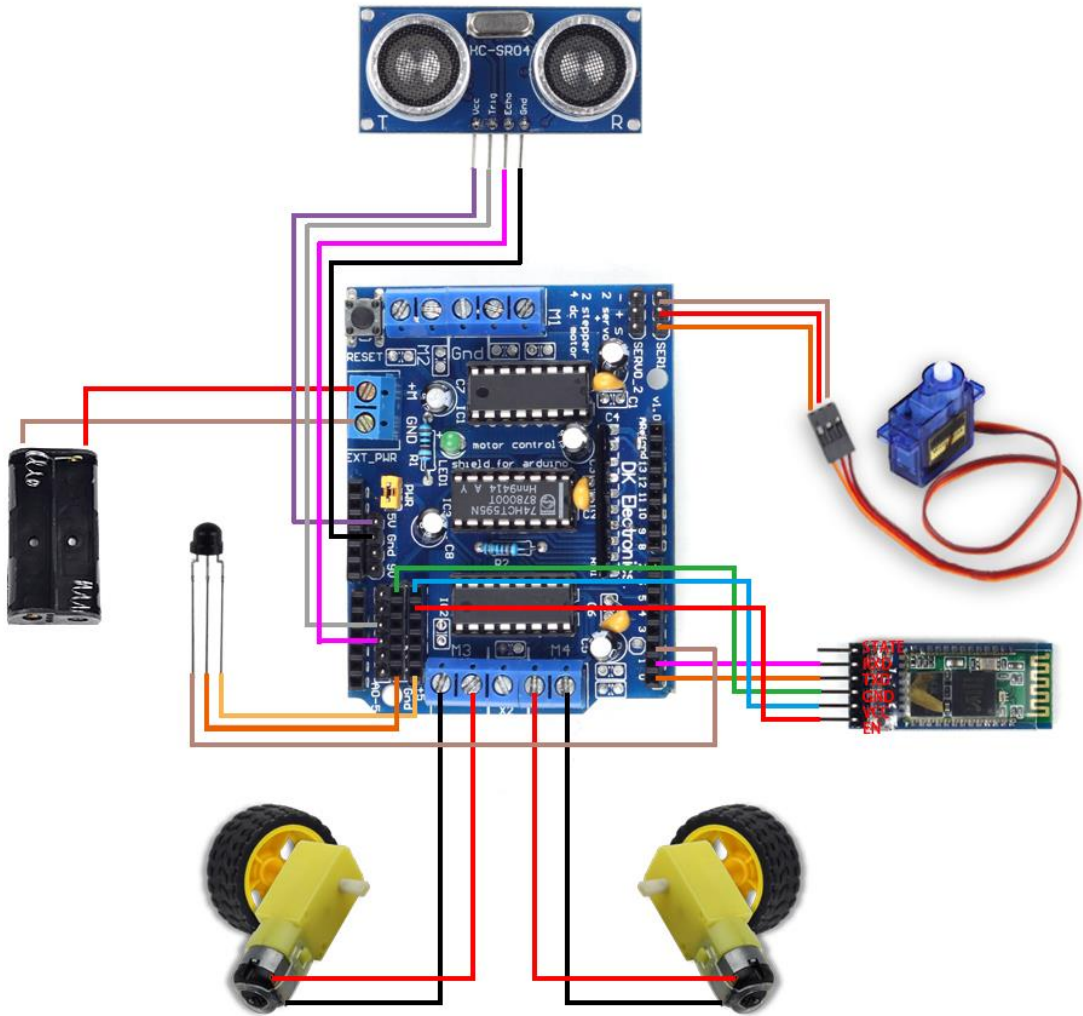

## 5. Installation

### 5.1 Installation of the Components

#### Step 1

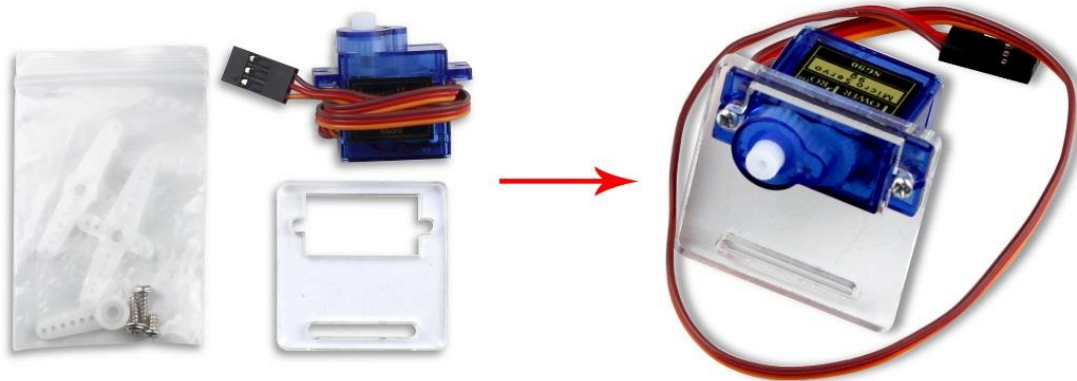

#### Step 2



Step 3

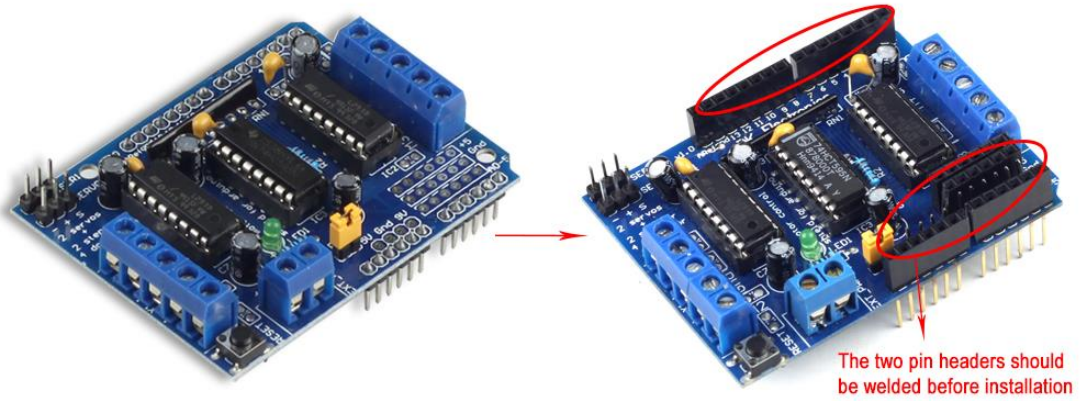

Step 4

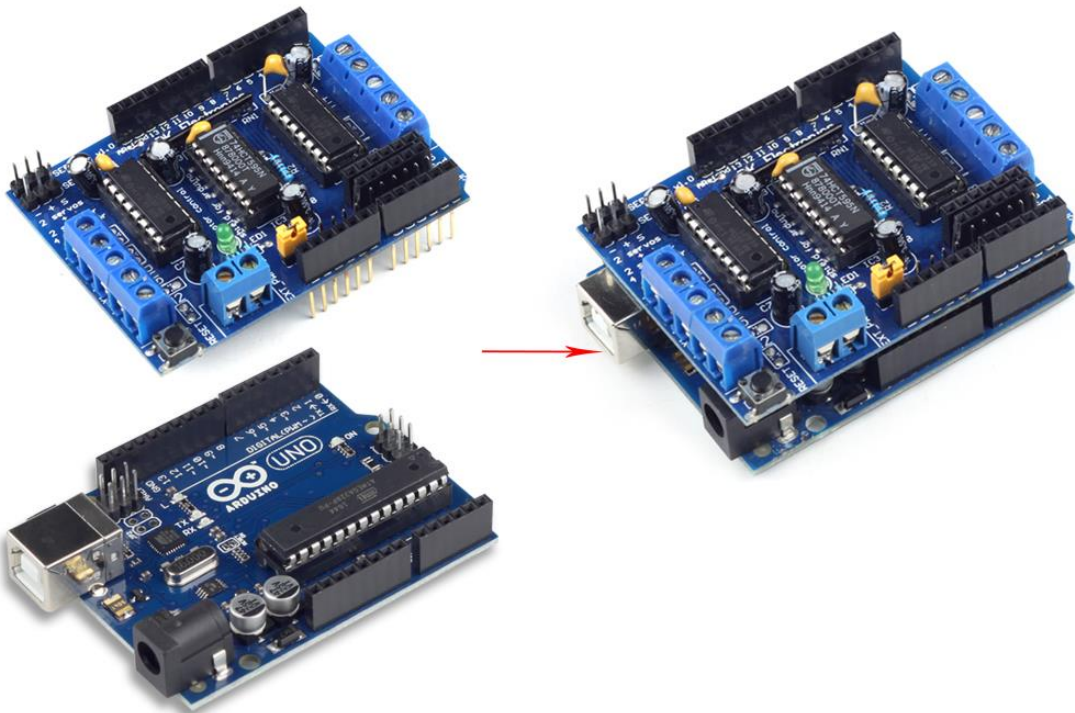

## 5.2 Installation of the Car

### Step 1: Install the deceleration DC motor to the chassis

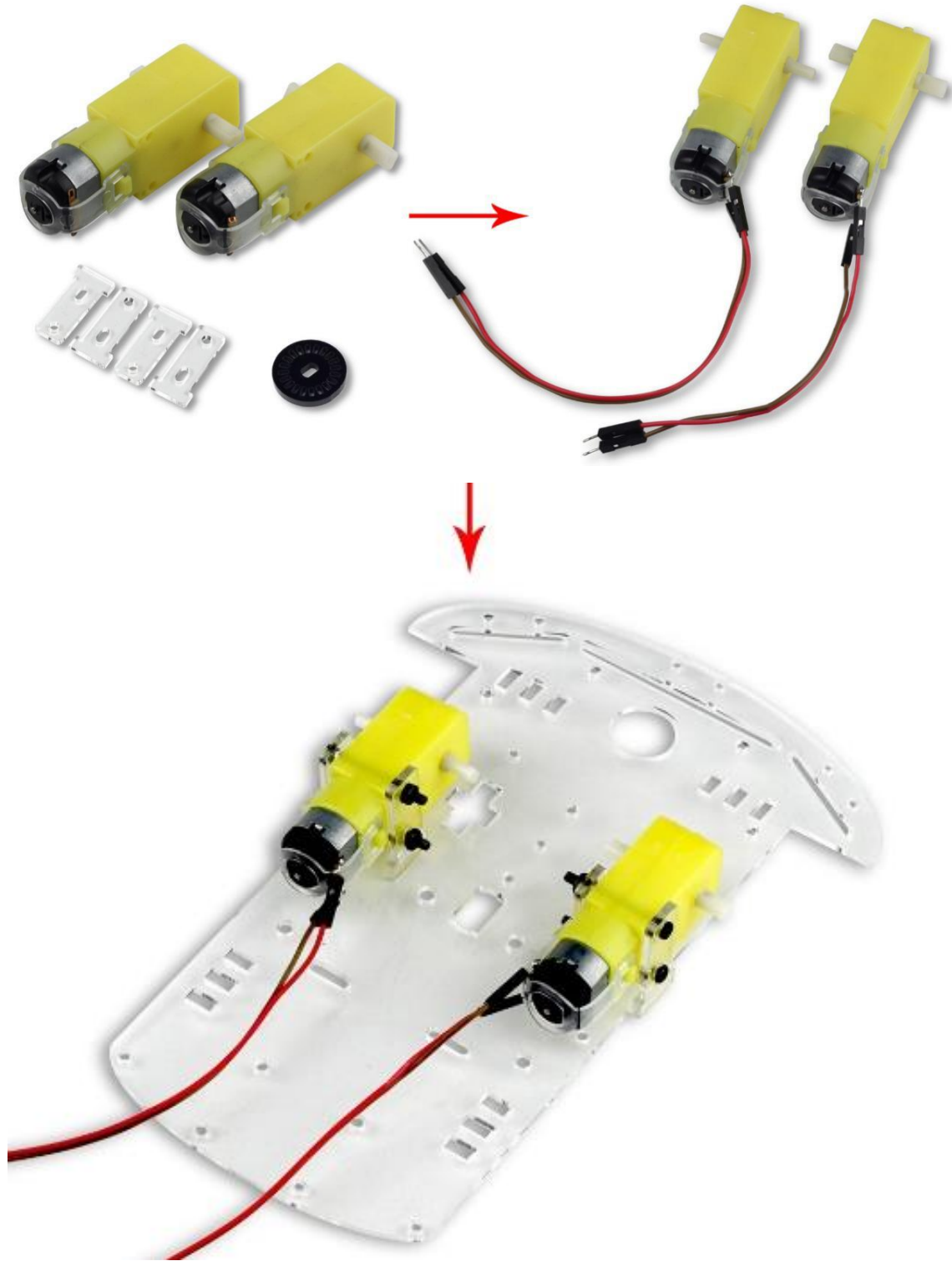

**Step 2: Install the hammer caster**



**Step 3: Fix the wheel**

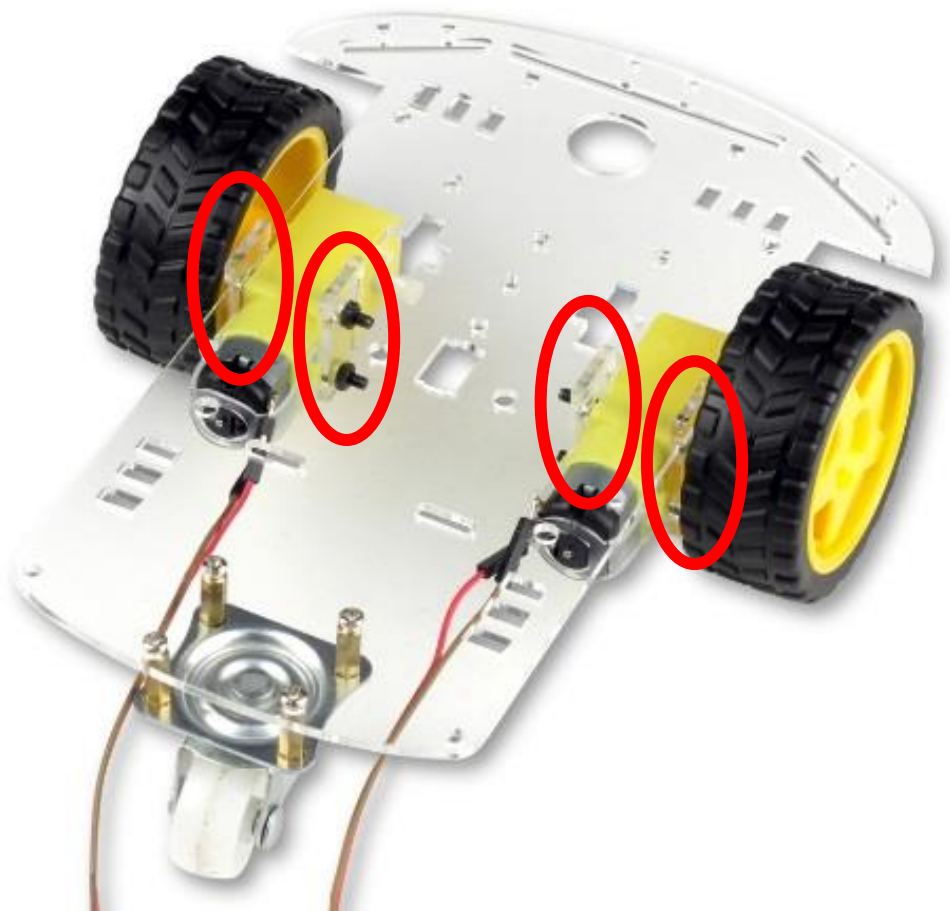

**Step 4: Connect the servo to the motor drive board**

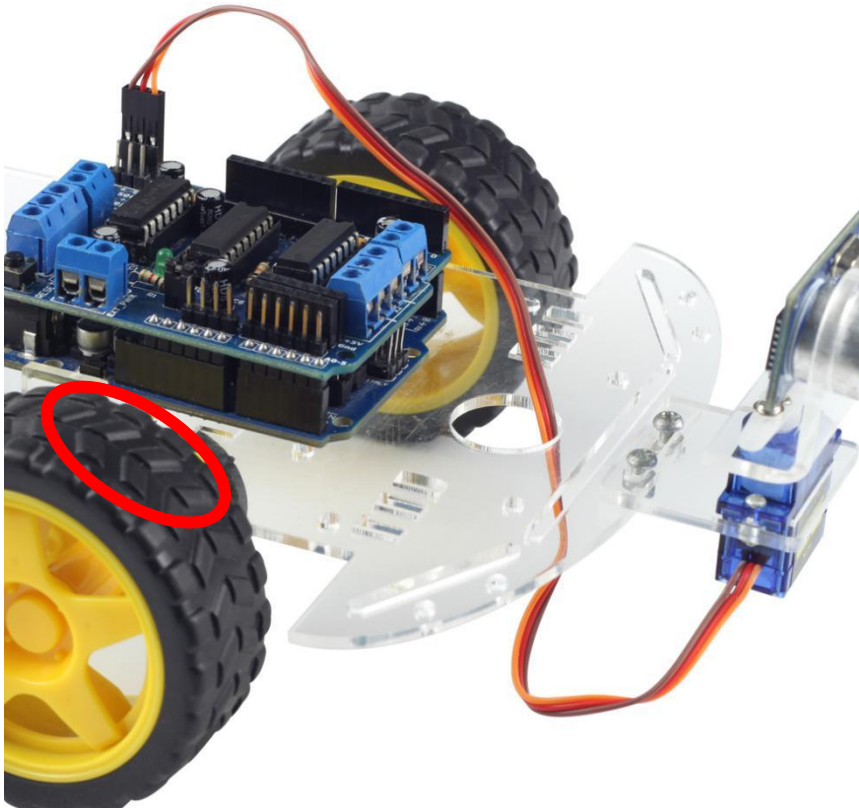

**Step 5: Install the ultrasonic bracket**

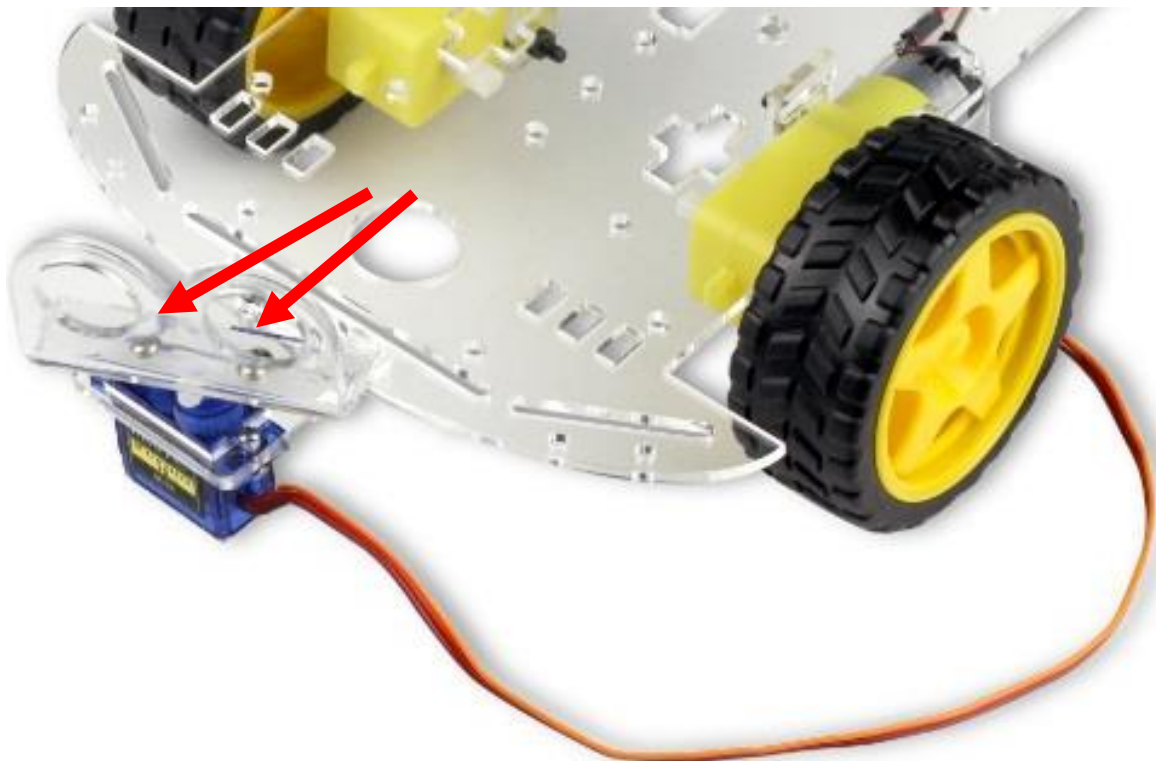

**Step 6: Install the ultrasonic module**

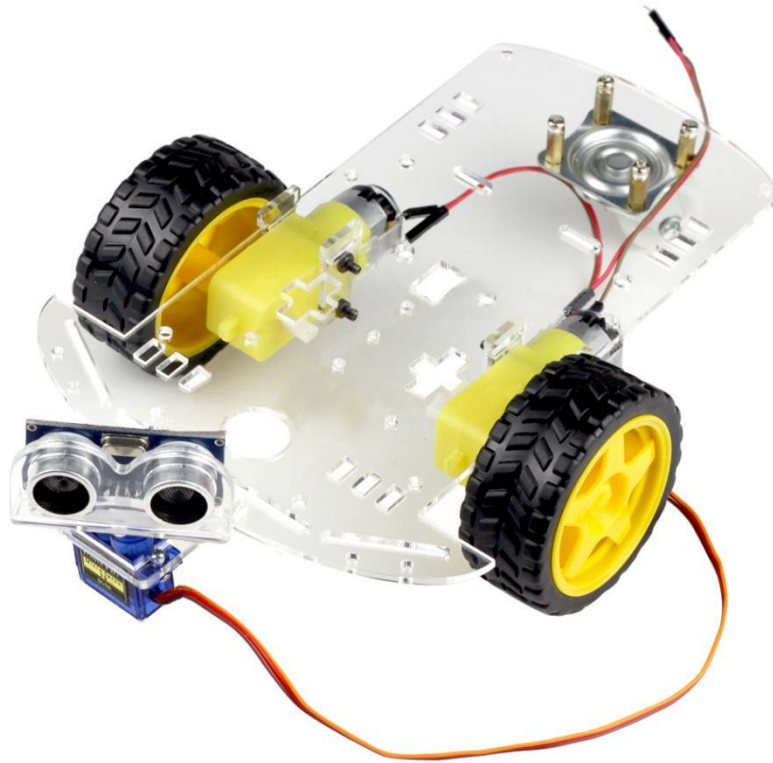

**Step 7: Connect the infrared sensor**

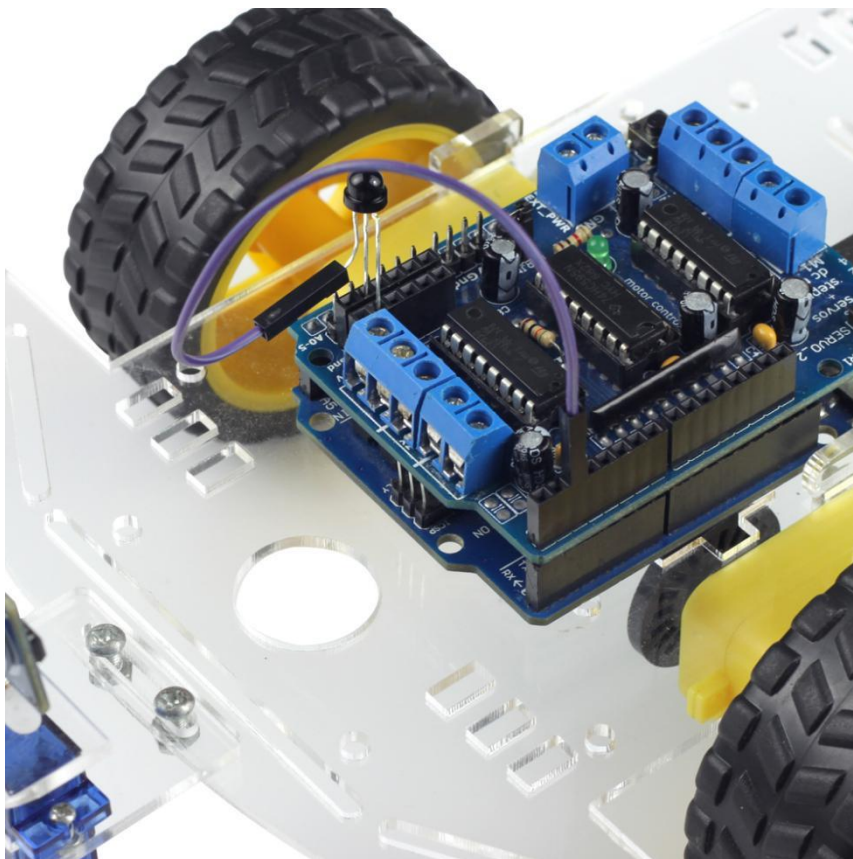

**Step 8: Place the battery container**

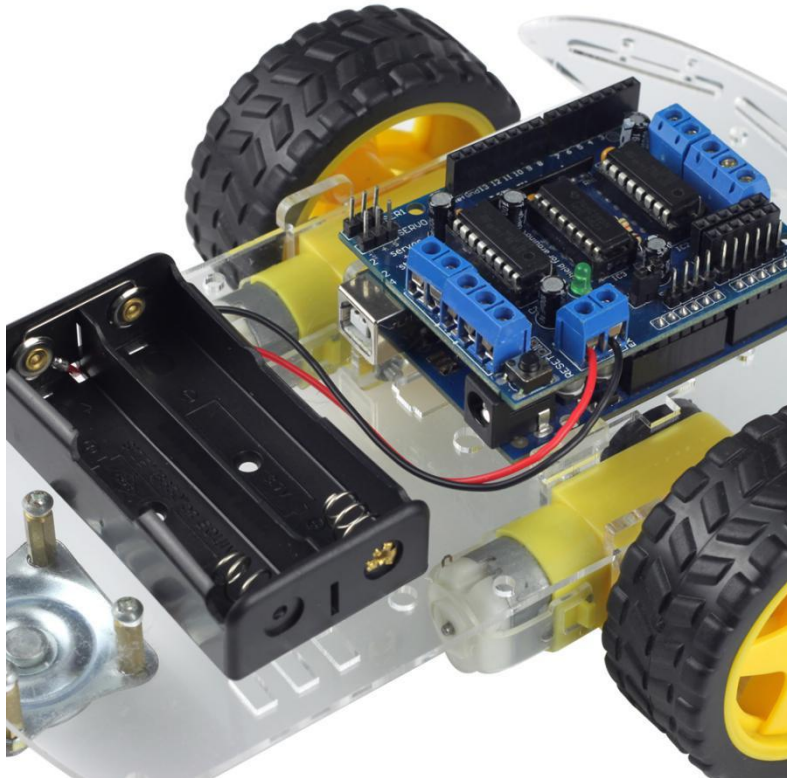

**Step 9: Connect remote controller wire to the motor drive board**

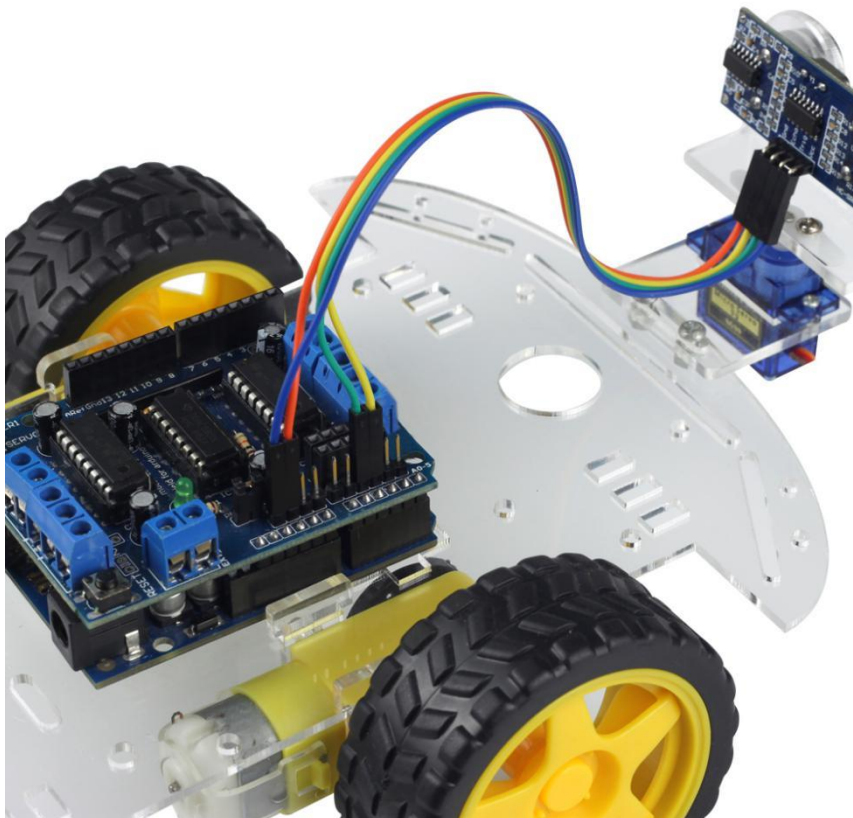

**Step 10: Install the HC-05 Bluetooth module**

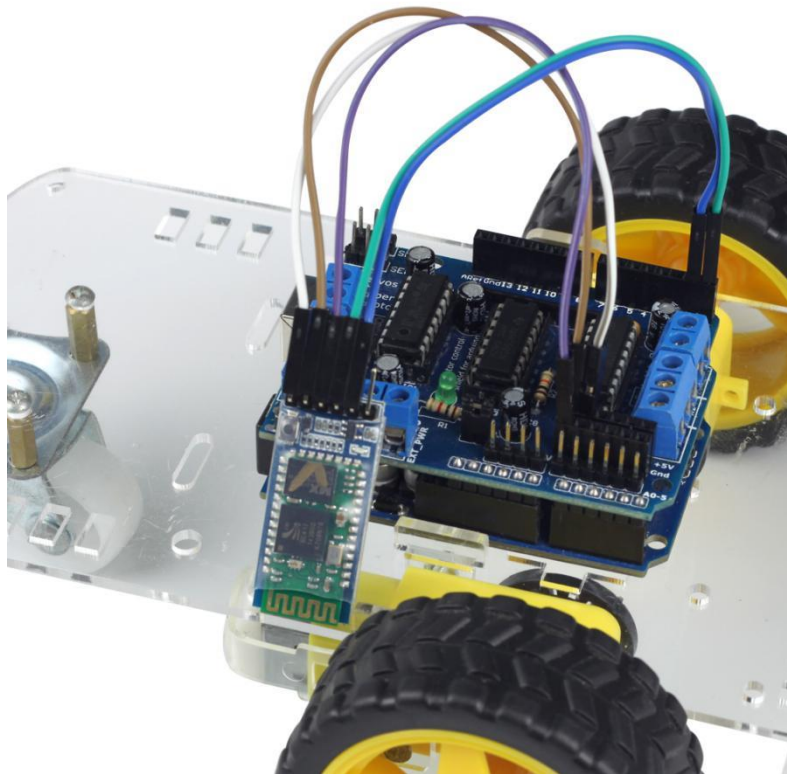

**Step 11: Connect the motor drive board to the deceleration DC motor**



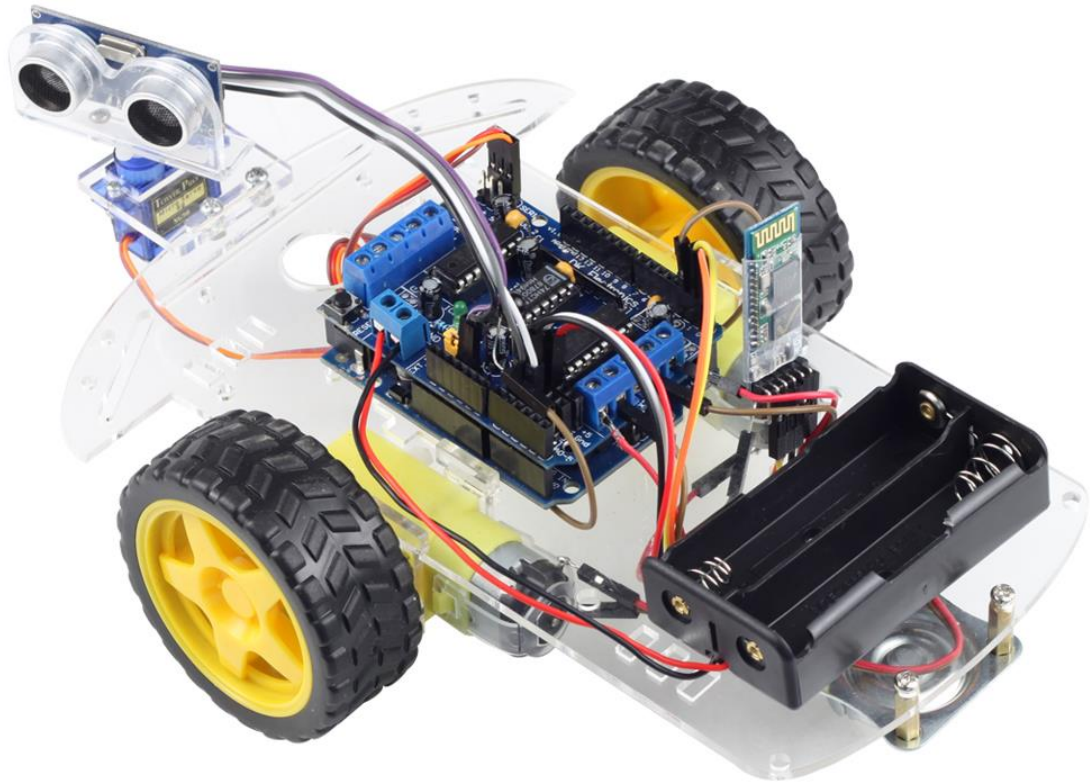

## 6. Key Value for Remote Controller



## 7. Start Programing

### 7.1 Install Arduino IDE

**Step 1:** Go to the arduino.cc website and click Software. On the page, check the software list on the right side under Download the Arduino Software

#### Download the Arduino IDE

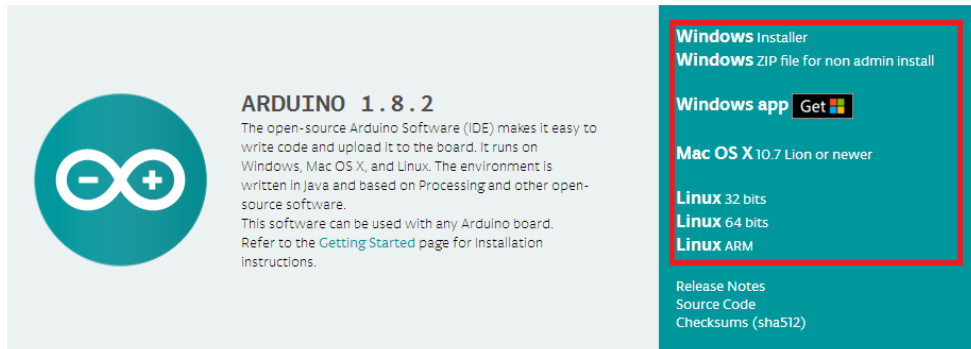

Find the one that suits your operation system and click to download. There are two versions of Arduino for Windows: Installer or ZIP file. You're recommended to download the former

**Step 2:** Press the button "JUST DOWNLOAD" to download the software

#### Support the Arduino Software

Consider supporting the Arduino Software by contributing to its development. (US tax payers, please note this contribution is not tax deductible). [Learn more on how your contribution will be used.](#)

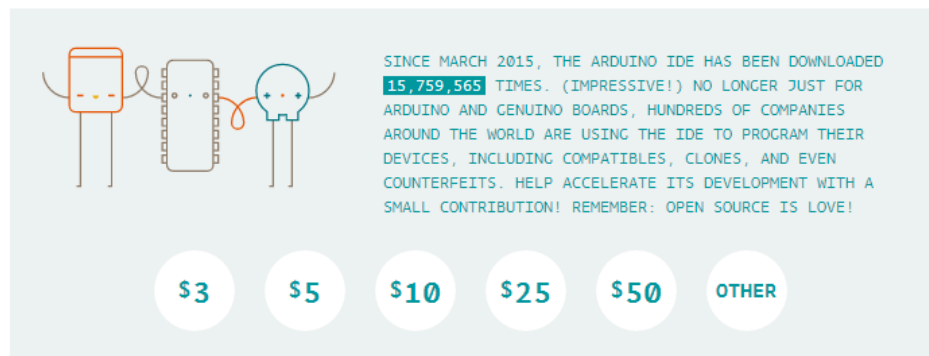

**Step 3:** Double click the .exe file and the following window will show up. Click "I Agree"

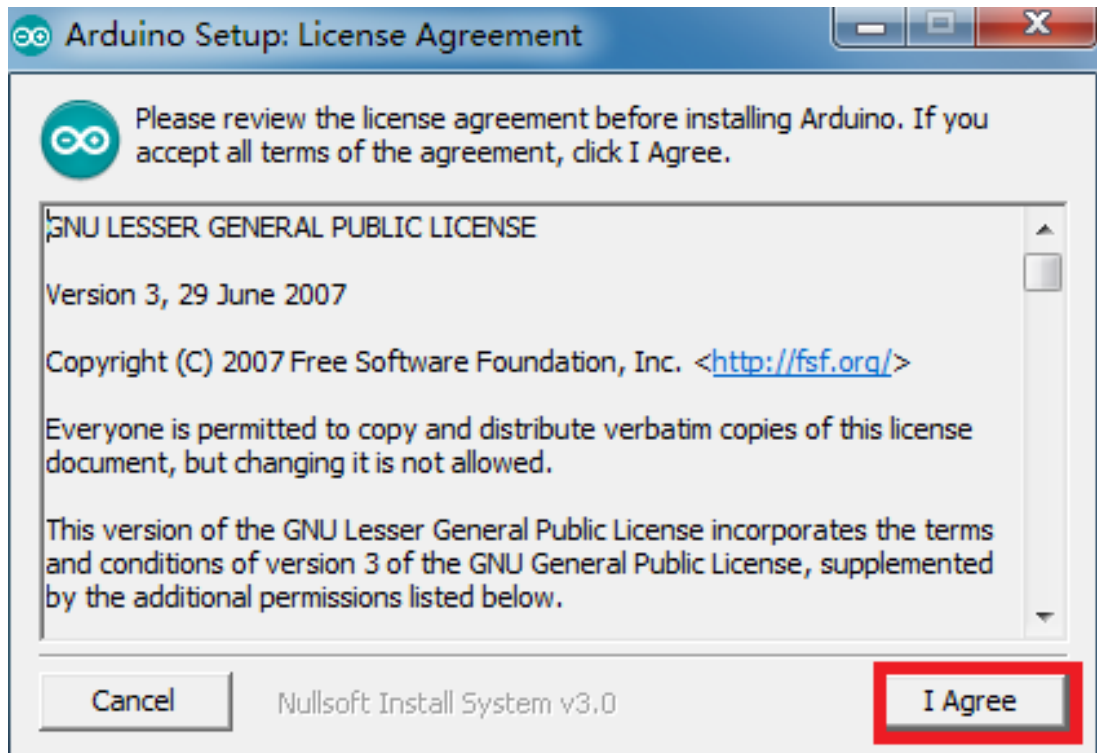

Next

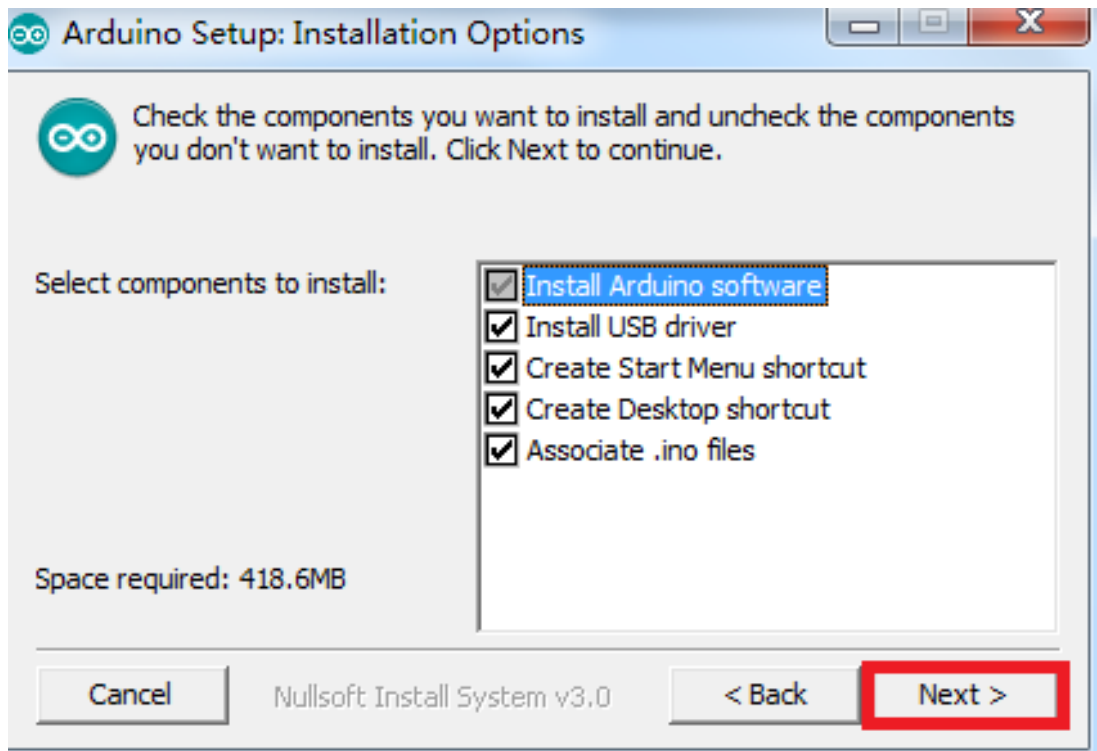

**Step 4:** Click “Browse” to choose the installation path or enter a directory at the Destination Folder. Click “Install” to initiate installation

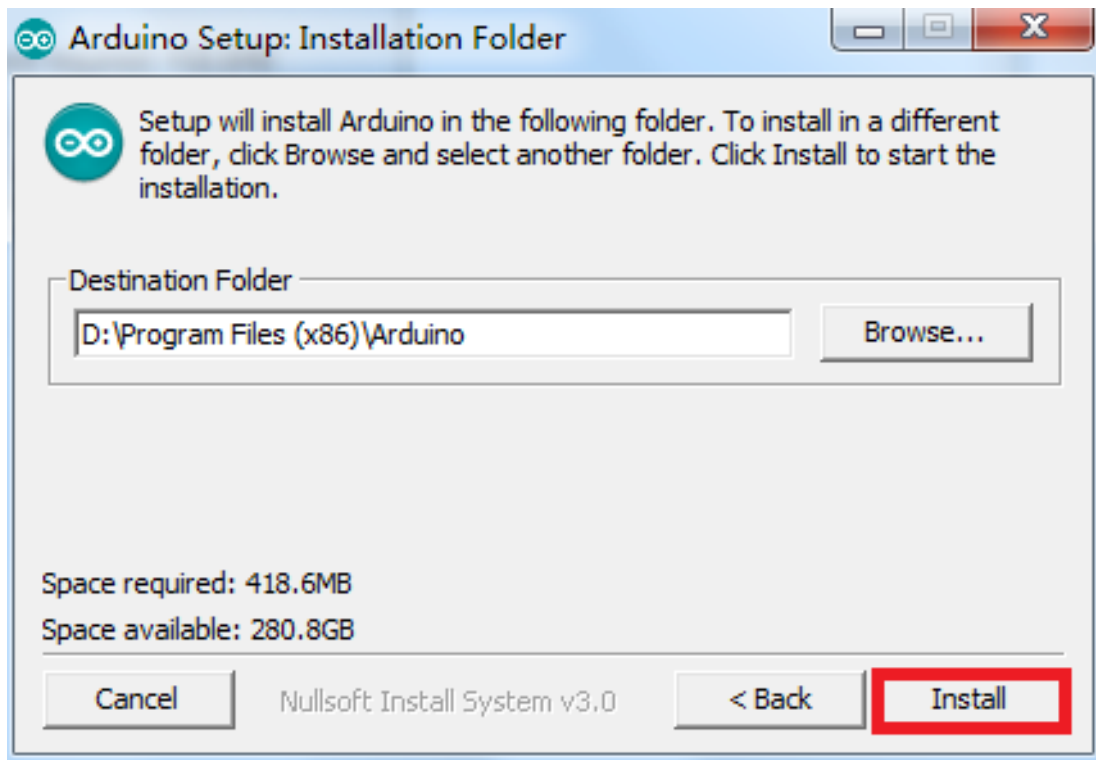

**Step 5:** After the installing progress bar goes to the end, the “Close button” may be enabled for some PC. Just click it to complete the installation

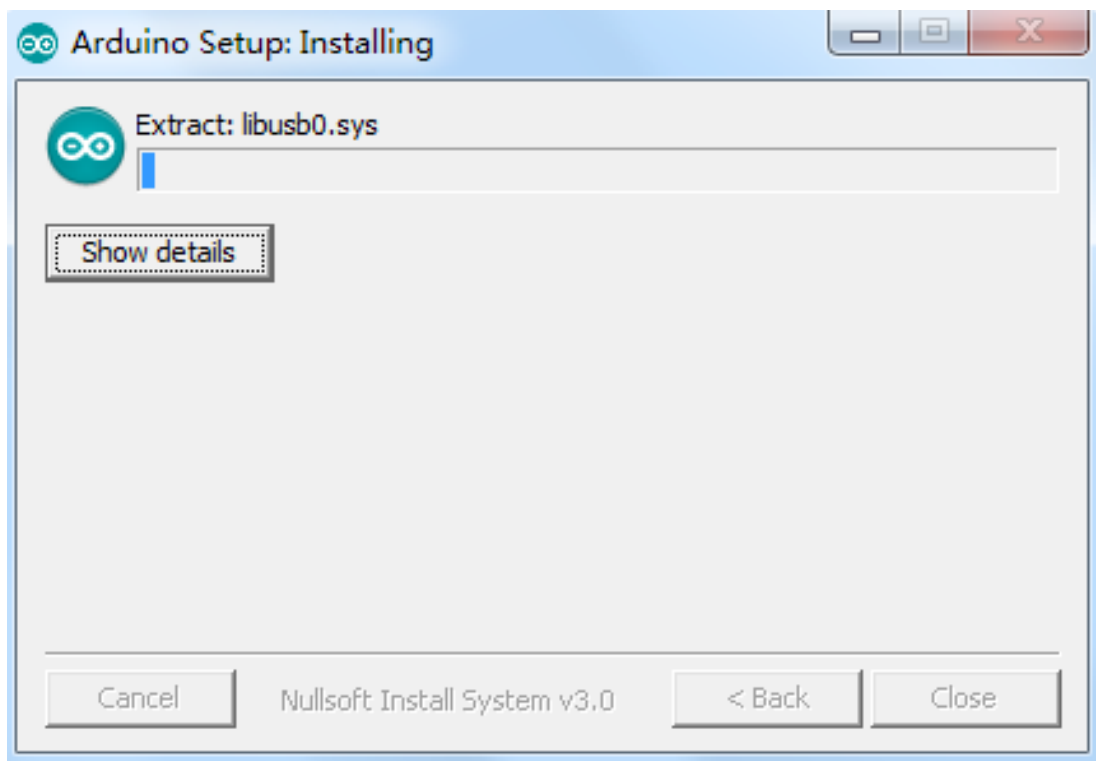

**Step 6:** Then a prompt appears. Select Always trust software for "Adafruit Industries" and click "Install"

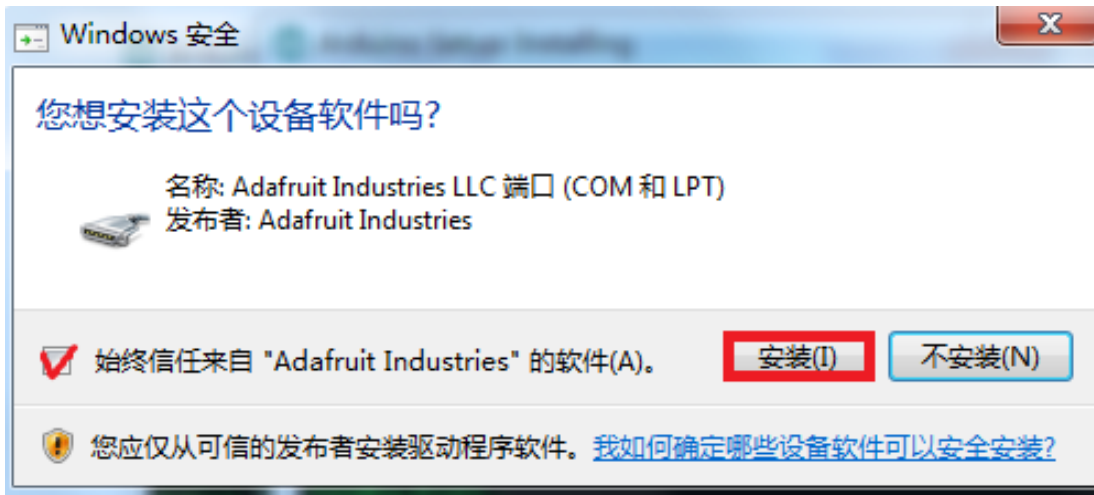

**Step 7:** After the installation is done, click Close. Then an Arduino icon will appear on the desktop:

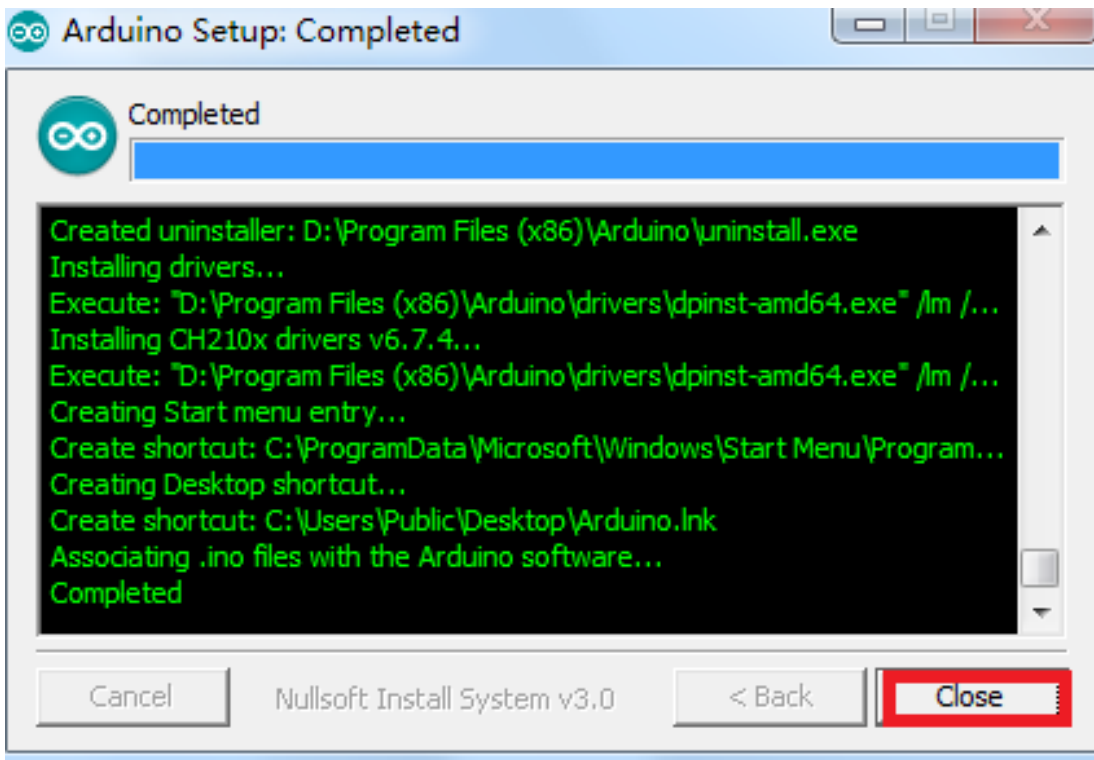

## 7.2 Add Libraries

**Step 1:** Download and unzip the file

<https://github.com/UCTRONICS/Smart-Robot-Car-Arduino.git>

**Step 2:** Open the documents “Smart-Robot-Car-Arduino-master”



And then, Copy “Arducam\_Smart\_Robot\_Car” to .. \ Arduino \ libraries (under the installation path of Arduino)

Open the “Install Library” copy “AFMotor”, “NewPing” to .. \ Arduino \ libraries (under the installation path of Arduino)

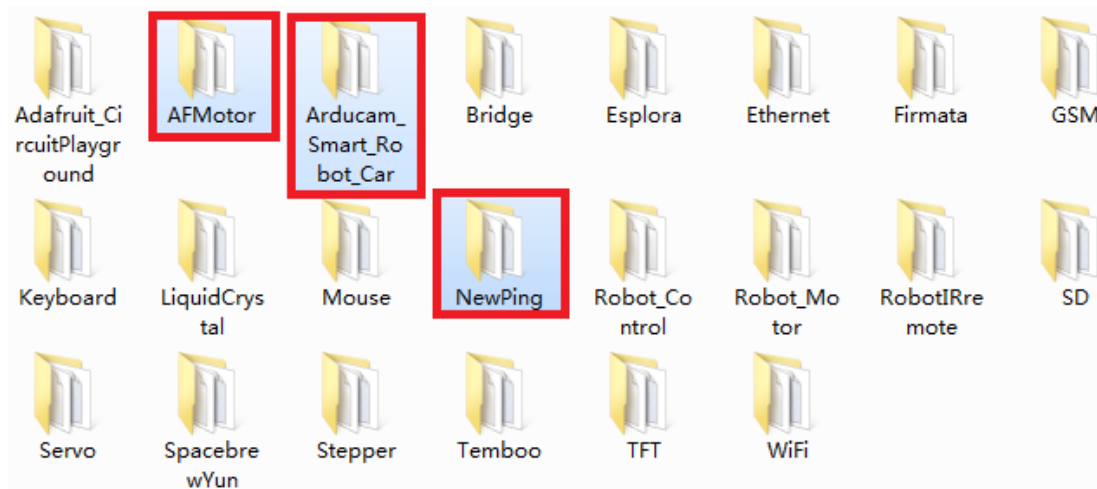

**Step 3:** Open Arduino IDE, click “Tools” -> “Board: Arduino/Genuino Uno” -> “Arduino/Genuino Uno”

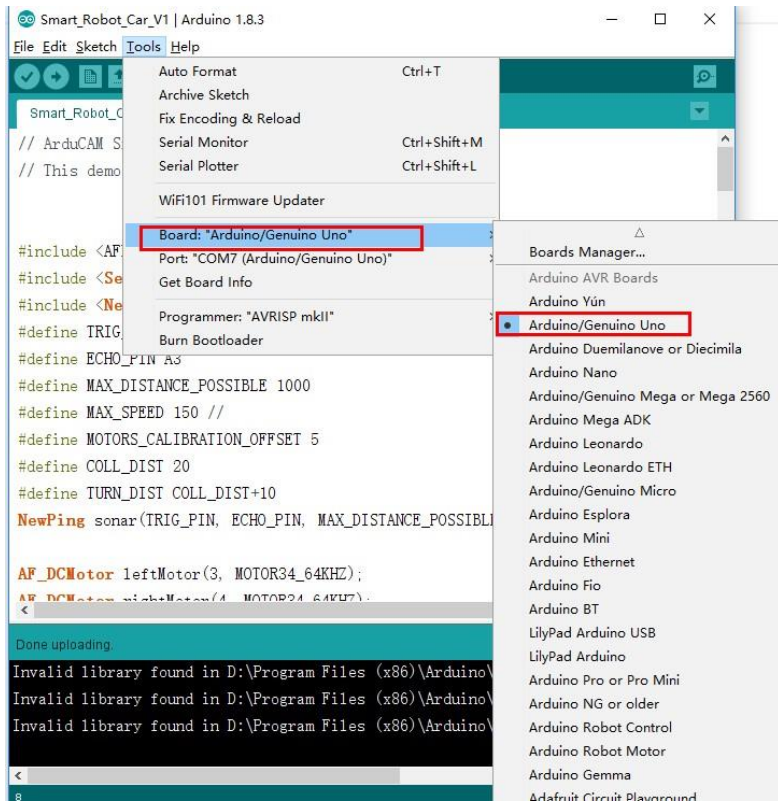

**Step 4:** Click “Tool” to select the serial port

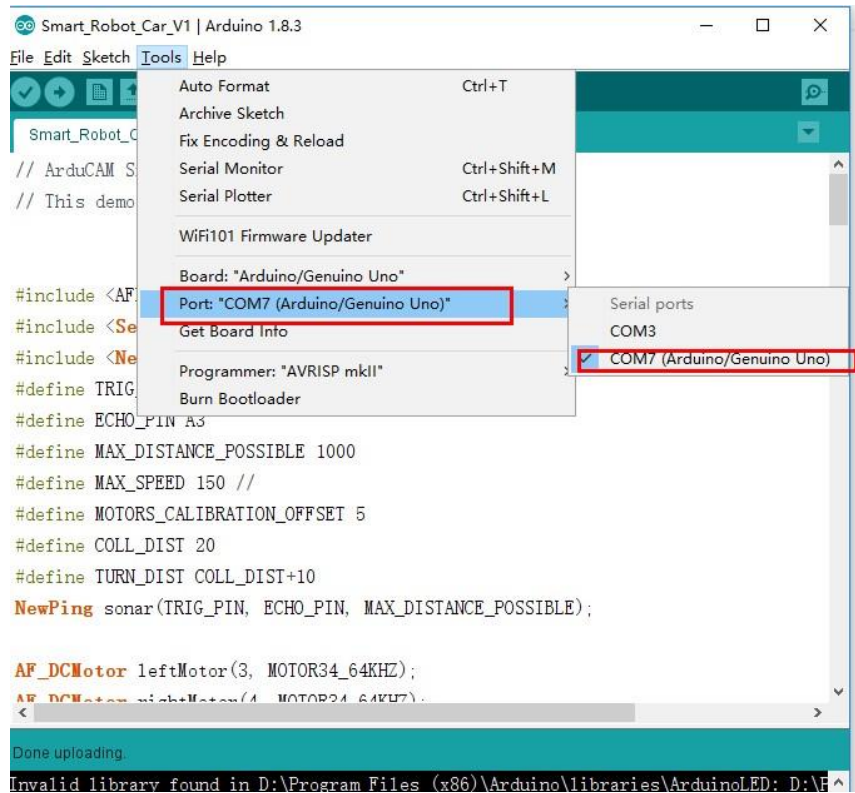

**Step 5:** Click “File” to select the library

**Please note** that the Arducam smart robot car V1 support smart mode, Arducam smart robot car V2 add the support of Bluetooth control and IR control

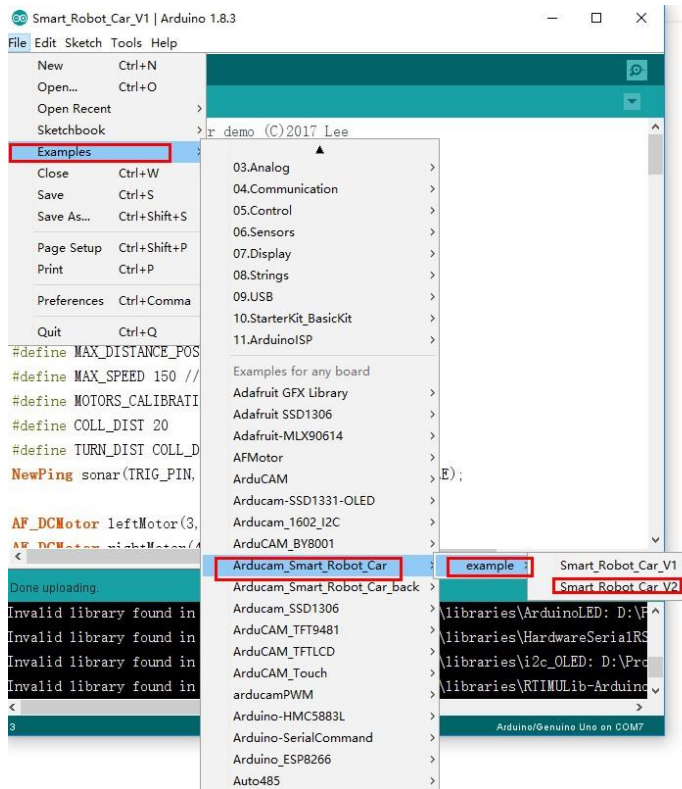

**Step 6:** Compile and download

**Please note** that before compiling, you should remove the HC-05 Bluetooth module

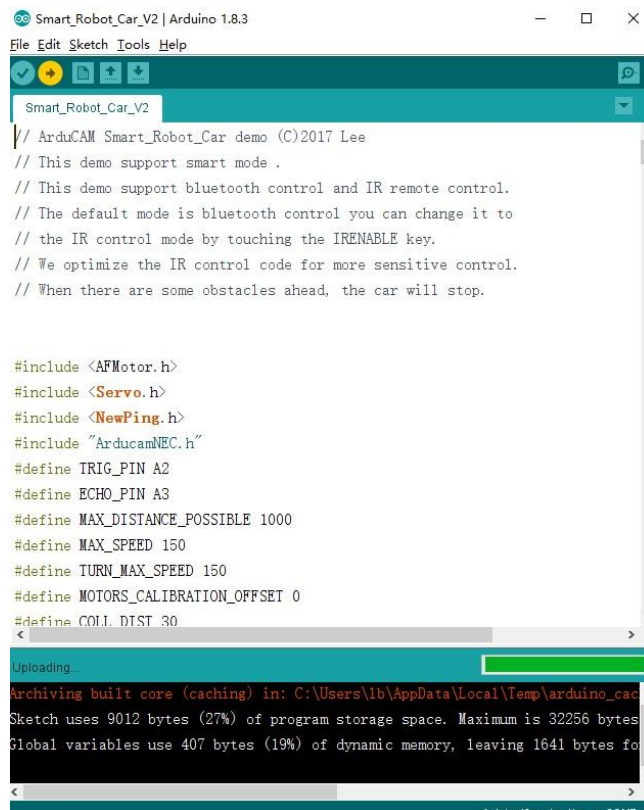

## 8. Bluetooth App for Android

### Step 1: Download and Install App

<https://github.com/UCTRONICS/Smart-Robot-Car-Arduino/tree/master/BlueTooth%20Tool>

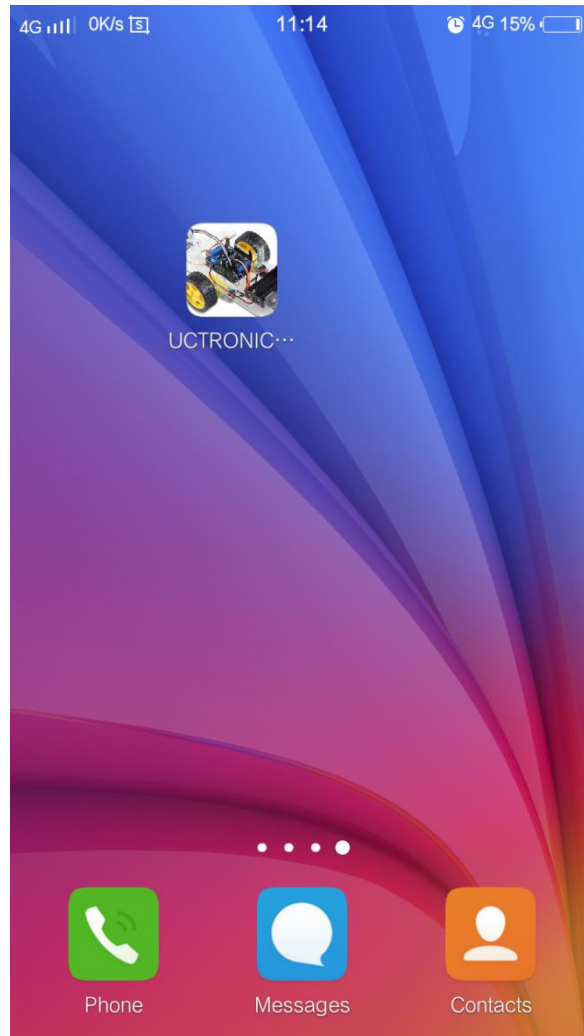

**Step 2: Open UCTRONICS\_Car\_Controller software, the default is Bluetooth Mode**

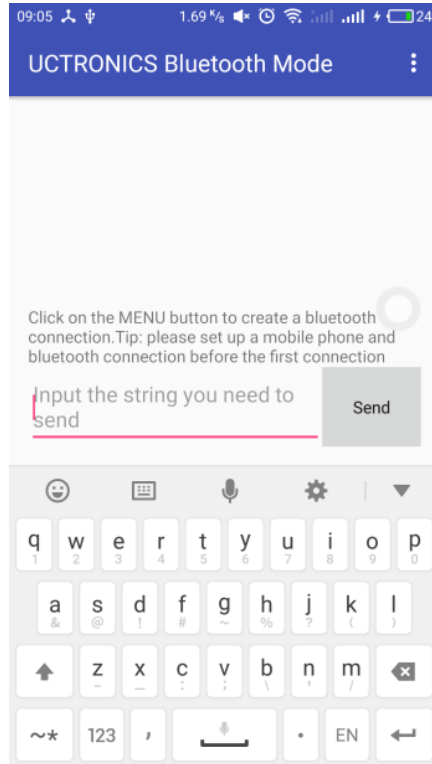

**Step 3: Click the top right and choose 'Connected device'**

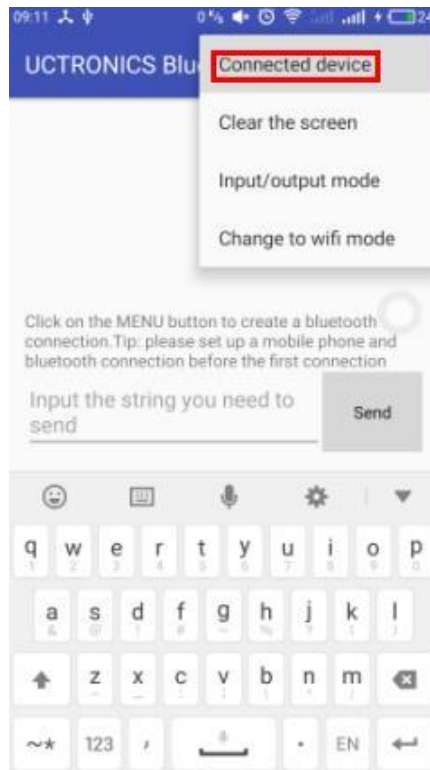

**Step 4: Select 'CAR CONTROL MODE'**

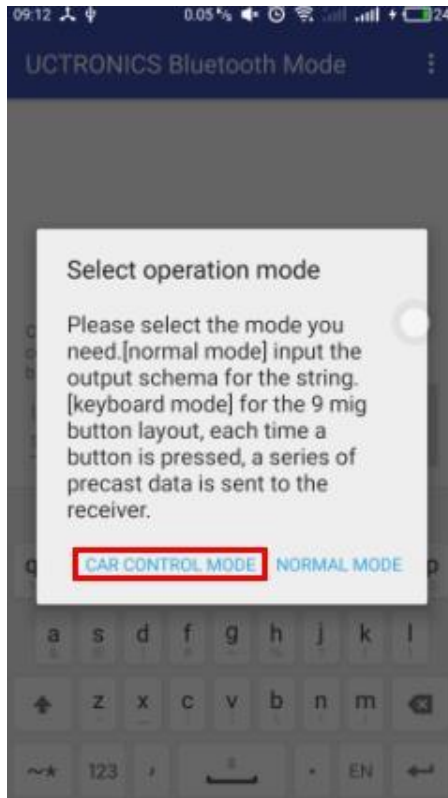

**Step 5: Search Bluetooth Device**

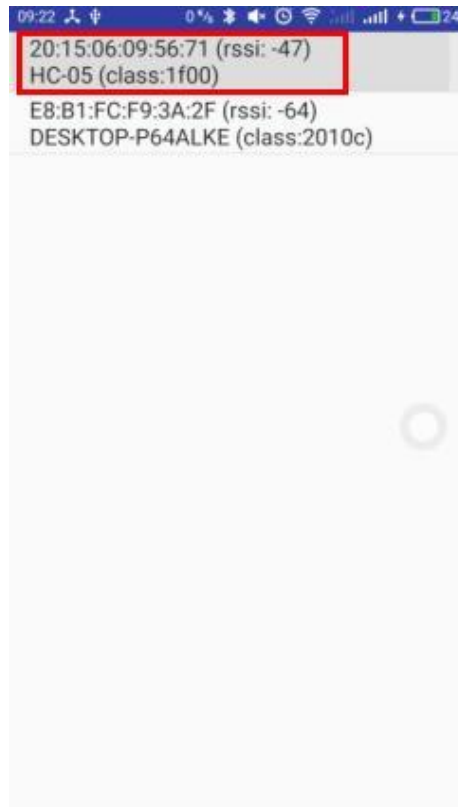

Step 6: Enter control menu

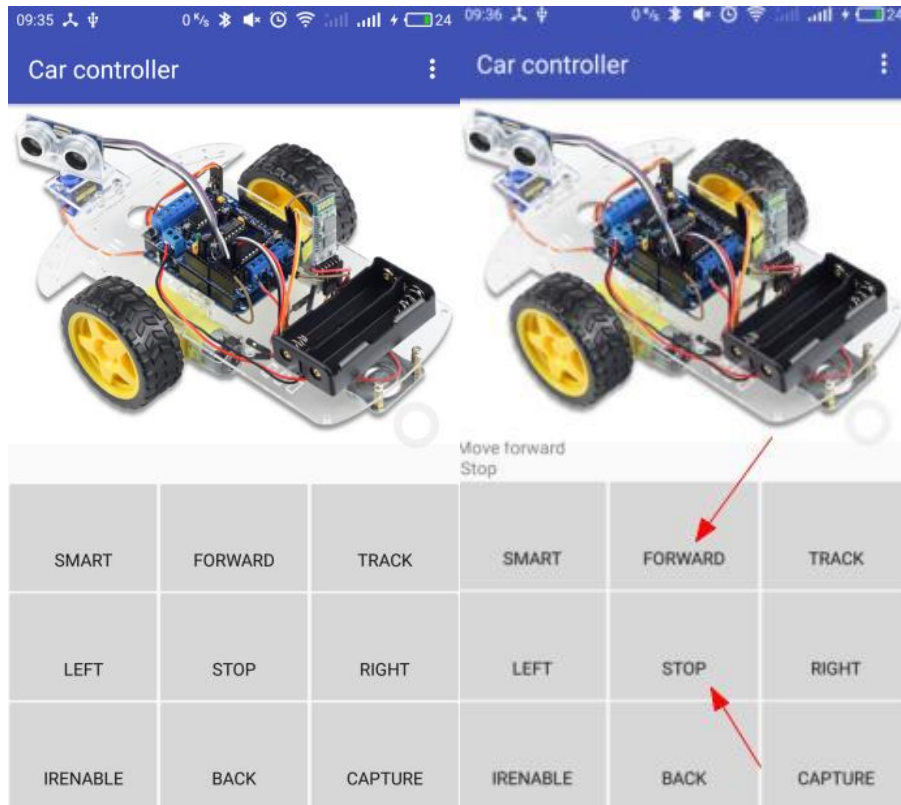

Step 7: Click the top right and choose 'Change to wifi mode'

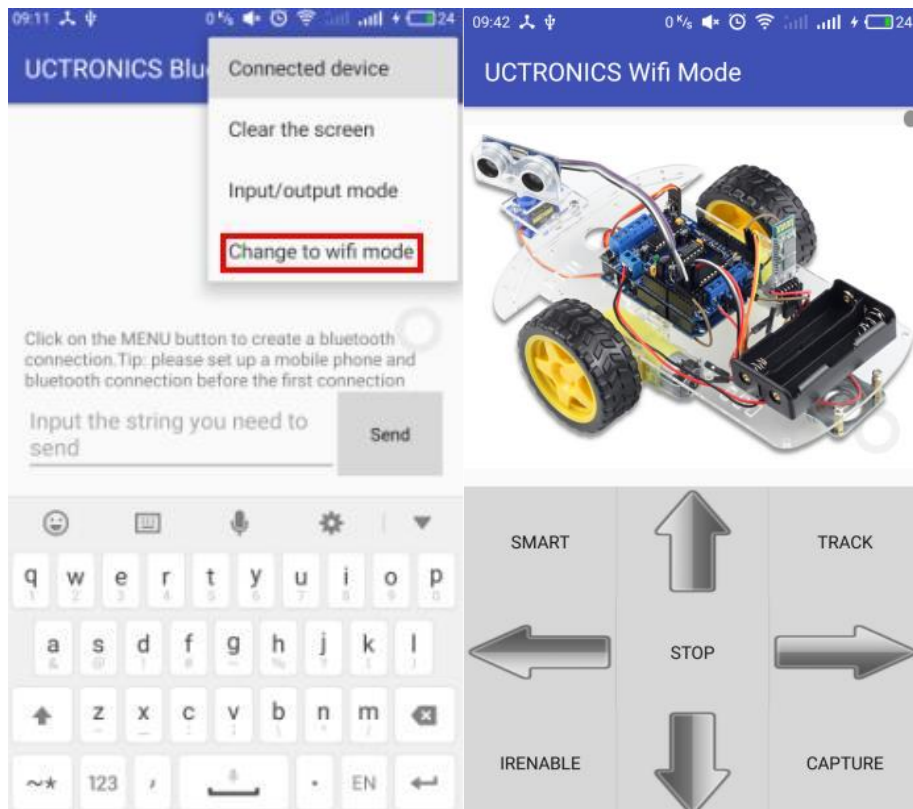

For examples and documentation, please visit:

<https://github.com/UCTRONICS/Smart-Robot-Car-Arduino.git>

If any problems or suggestions for the tutorial or the robot car, please feel free to contact us by following ways:

Skype: fpga4u

Tel: +86 025 84271192

Website: [www.uctronics.com](http://www.uctronics.com)

Email: [sales@uctronics.com](mailto:sales@uctronics.com)